

Total solder points: 600

Difficulty level:

beginner 1 2 3 4 5 advanced



MONO PURE CLASS A VALVE POWER AMPLIFIER

K8010

- ⇒ Pure CLASS A valve sound with high quality KT88 valves
- ⇒ High quality chrome plated enclosure
- ⇒ Chrome plated valve socket covers
- ⇒ Easy bias adjustment with LED indication
- ⇒ Removable bottom for easy access and service
- ⇒ High quality capacitors and components
- ⇒ Gold plated input and speaker terminals
- ⇒ Standby function
- ⇒ Soft start circuit for power transformer
- ⇒ Sensitivity adjustment for exact matching of two mono amps

Specifications

- Full class A 65Wrms in 4 or 8Ω
- Bandwidth: 4Hz to 90KHz (-3dB/1W)
- Harmonic distortion: 0.1% @ 1W/1KHz
- Signal to noise ratio: >110dB (A weighted)
- Input sensitivity: 1Vrms (adjustable)
- Power supply: 100, 120, 230 or 245VAC
- Power consumption: 230VA max.
- Dimensions: 355W x 360D x 157H
- Weight: 14Kg / 31lb

modifications reserved

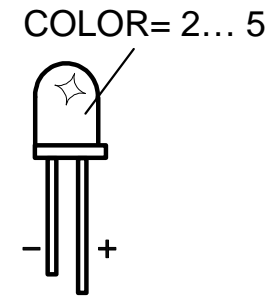
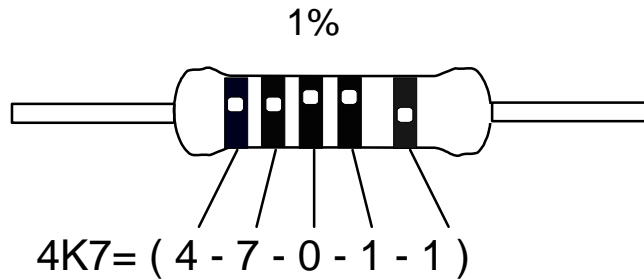
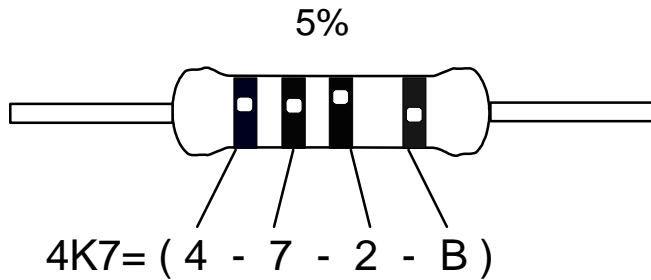

C O D E	I	P	E	SF	S	DK	N	D	GB	F	NL	C O D E
	<i>CODICE COLORE</i>	<i>CODIGO DE CORES</i>	<i>CODIGO DE COL- ORES</i>	<i>VÄRI KOODI</i>	<i>FÄRG SCHEMA</i>	<i>FARVE KODE</i>	<i>FARGE KODE</i>	<i>FARB KODE</i>	<i>COLOUR CODE</i>	<i>CODIFI- CATION DES COU- LEURS</i>	<i>KLEUR KODE</i>	
0	Nero	Preto	Negro	Musta	Svart	Sort	Sort	Schwarz	Black	Noir	Zwart	0
1	Marrone	Castanho	Marrón	Ruskea	Brun	Brun	Brun	Braun	Brown	Brun	Bruin	1
2	Rosso	Encarnado	Rojo	Punainen	Röd	Rød	Rød	Rot	Red	Rouge	Rood	2
3	Aranciato	Laranja	Naranjado	Oranssi	Orange	Orange	Orange	Orange	Orange	Orange	Oranje	3
4	Giallo	Amarelo	Amarillo	Keltainen	Gul	Gul	Gul	Gelb	Yellow	Jaune	Geel	4
5	Verde	Verde	Verde	Vihreä	Grön	Grøn	Grønn	Grün	Green	Vert	Groen	5
6	Blu	Azul	Azul	Sininen	Blå	Blå	Blå	Blau	Blue	Blue	Blauw	6
7	Viola	Violeta	Morado	Purppura	Lila	Violet	Violet	Violet	Purple	Violet	Paars	7
8	Grigio	Cinzeno	Gris	Harmaa	Grå	Grå	Grå	Grau	Grey	Gris	Grijs	8
9	Bianco	Branco	Blanco	Valkoinen	Vit	Hvid	Hvidt	Weiss	White	Blanc	Wit	9
A	Argento	Prateado	Plata	Hopea	Silver	Sølv	Sølv	Silber	Silver	Argent	Zilver	A
B	Oro	Dourado	Oro	Kulta	Guld	Guld	Guldl	Gold	Gold	Or	Goud	B

TECHNICAL DATA*



- Output power: 65 Wrms class A / 85Wrms maximum
- Output impedance 4 or 8 Ohm
- Ultra linear output transformer
- Switch-on delay, to protect the output tubes: approx. 1 minute
- Standby circuit
- Built-in bias current indicator
- Switch-on delay for the supply transformer : 0.5s
- Power bandwidth: 8Hz - 45kHz (-3dB, ref. 50W)
- Frequency range: 4Hz - 90kHz (-3dB, ref. 1W)
- Harmonic distortion:
 - 0.1% (1 kHz/1W)
 - 0.7% (1 kHz/65W)
- Signal/noise ratio: > 110dB (A weighted wrt 85W)
- Input impedance: 100Kohm
- Input sensitivity min 1Vrms, adjustable.
- Damping factor (100Hz): > 12
- Power supply: 100, 120, 230, 245VAC
- Power consumption: 230Wmax. / 66W standby
- Dimensions: 355W x 360D x 157H

*Modifications and typographical errors reserved

1. Assembly (Skipping this can lead to troubles !)

Ok, so we have your attention. These hints will help you to make this project successful. Read them carefully.

1.1 Make sure you have the right tools:

- A good quality soldering iron (25-40W) with a small tip.
- Wipe it often on a wet sponge or cloth, to keep it clean; then apply solder to the tip, to give it a wet look. This is called 'thinning' and will protect the tip, and enables you to make good connections. When solder rolls off the tip, it needs cleaning.
- Thin raisin-core solder. Do not use any flux or grease.
- A diagonal cutter to trim excess wires. To avoid injury when cutting excess leads, hold the lead so they cannot fly towards the eyes.
- Needle nose pliers, for bending leads, or to hold components in place.
- Small blade and phillips screwdrivers. A basic   range is fine.

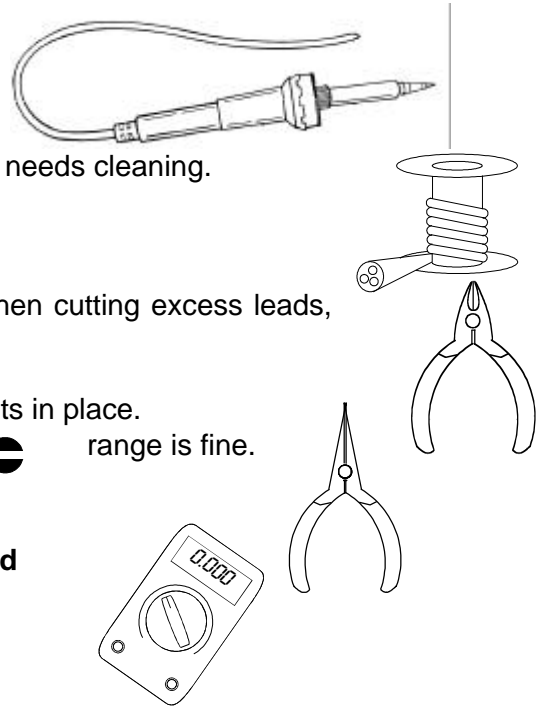

For this projects, a basic multi-meter is required

1.2 Assembly Hints :

- ⇒ Make sure the skill level matches your experience, to avoid disappointments.
- ⇒ Follow the instructions carefully. Read and understand the entire step before you perform each operation.
- ⇒ Perform the assembly in the correct order as stated in this manual
- ⇒ Position all parts on the PCB (Printed Circuit Board) as shown on the drawings.
- ⇒ Values on the circuit diagram are subject to changes.
- ⇒ Values in this assembly guide are correct*
- ⇒ Use the check-boxes to mark your progress.
- ⇒ Please read the included information on safety and customer service

* Typographical inaccuracies excluded. Always look for possible last minute manual updates, indicated as 'NOTE' on a separate leaflet.

1.3 Soldering Hints :

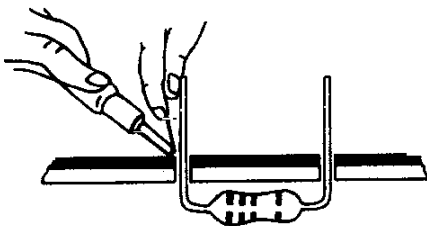

Mount the component against the PCB surface and carefully solder the leads

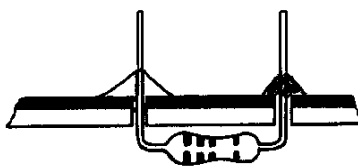

Make sure the solder joints are cone-shaped and shiny

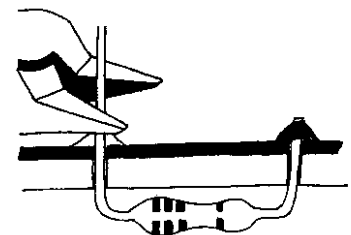

Trim excess leads as close as possible to the solder joint

ASSEMBLY OF THE MAIN PCB P8010:

Foreword:

For best results and easy handling of the large PCB (Printed Circuit Board), we will start by putting the four large valve sockets in place. This will allow us to rest the board on the bench, without having the component leads touching the bench surface.

When the component leads are put in the appropriate holes on the PCB, we recommend to gently bend the leads outwards, so they stay on the board when it is flipped over to apply solder. You gain a reasonable amount of time if you put approx. 10 components in place every time, before you flip the board, and make the solder joints.

1. VALVE SOCKET MOUNTING

Check the position of the notch in the centre of the valve socket, it must correspond to the position of the notch in the circle printed on the PCB. Connect the leads to the corresponding isles on the PCB using a small piece of supplied jumper wire.

IMPORTANT:

Make the connection exactly as shown in the illustration, otherwise the small piece of wire could touch the bottom of the cabinet, see further.

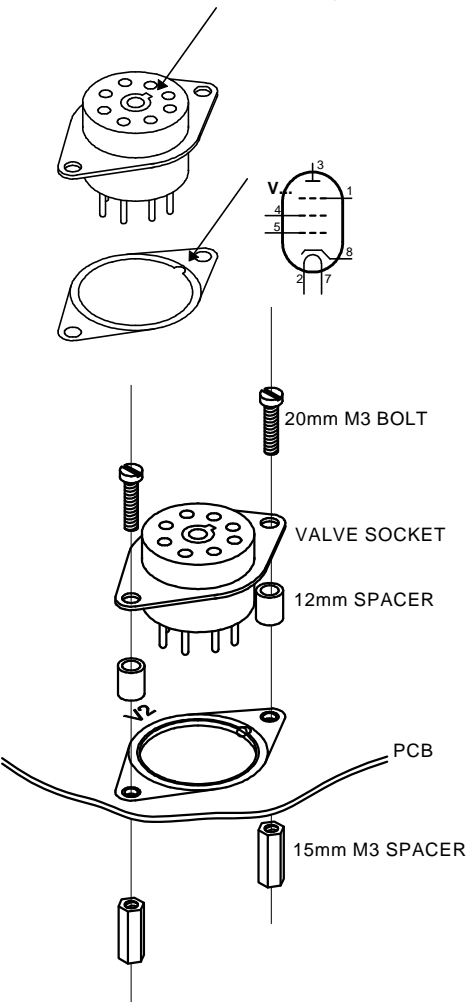

Also mount a 15 mm spacer on the following holes in the PCB (at the solder side); use a 6 mm M3 bolt:

- A spacer next to TRAF01
- A spacer next to SK15
- A spacer next to SK6
- A spacer next to R62
- A spacer next to V6

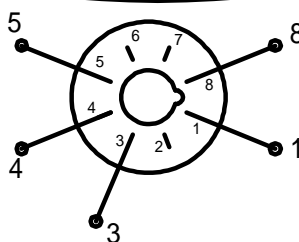
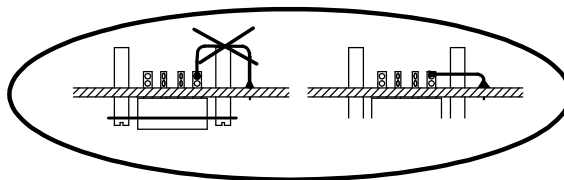
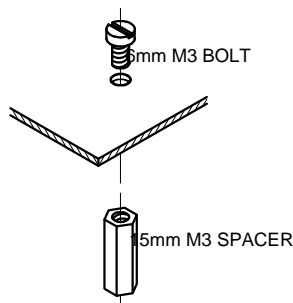

- V1 Connect the valve socket terminals 1, 3, 4, 5, and 8 to the corresponding points at the solder side of the PCB.
- V2
- V3 Use a piece of supplied jumperwire. Mount the wire in such way that it cannot touch the bottom of the cabinet. (see above illustration).
- V4

2. JUMPERS

Note that for J1 to J4, two jumper wires have to be mounted in the same hole, for extra current handling.

TIP

In order to get nice straight wiring, without too much folding and measuring, follow these hints:

- Put the jumper wire in place.
- Solder one end of the lead.
- Then carefully pull on the free end of the lead until it is straight, and apply solder.

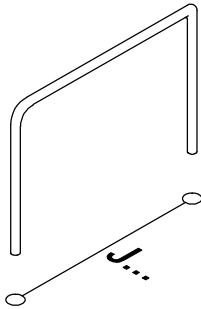

- J1 (mount 2 wires in the same hole)
- J2 (mount 2 wires in the same hole)
- J3 (mount 2 wires in the same hole)
- J4 (mount 2 wires in the same hole)
- J5
- J6
- J7
- J8
- J9
- J10
- J11
- J12
- J13
- J14
- J15
- J16
- J17
- J18
- J19
- J20
- J21
- J22 indicated with 'F1'
(mount 2 wires in the same hole)

3. JUMPERS FOR AC POWER SELECTION

For **100V** input (mains), mount:

- JA** at the voltage selection 1



- JA** at the voltage selection 2

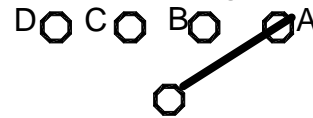

For **115V - 120V** input, mount:

- JB** at the voltage selection 1

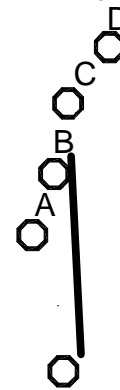

- JB** at the voltage selection 2

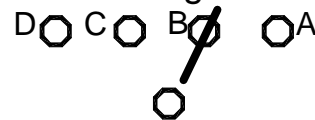

For **220V - 230V** input, mount:

- JC** at the voltage selection 1

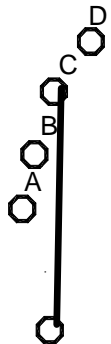

- JC** at the voltage selection 2

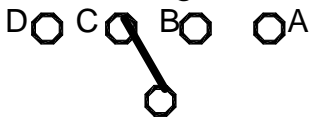

For **240V -245V** mains input, mount:

- JD** at the voltage selection 1

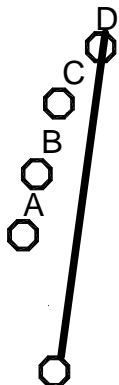

- JD** at the voltage selection 2

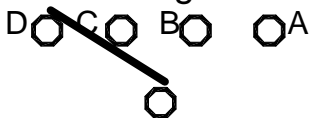

REMARK:

Strike out the NOT used mains voltage indication at the back of the enclosure !! Use a permanent black marker

4. DIODES (Check the polarity!)

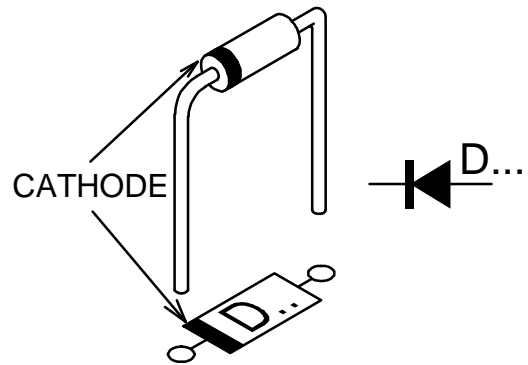

- D1: 1N4148
- D2 :1N4148
- D3: 1N4007
- D4: 1N4148
- D5: 1N4007
- D6: 1N4148
- D7: 1N4148
- D8: 1N4148
- D9: 1N4007
- D10: 1N4007
- D11: 1N4007
- D12: 1N4007
- D13: 1N4007
- D14: 1N4007
- D15: 1N4007
- D16: 1N4007
- D17: 1N4007
- D18: 1N4007
- D19: 1N4007
- D20: 1N4007
- D21: 1N4007
- D22: 1N4007
- D23: 1N4007
- D24: 1N4148
- D25: 1N4148
- D26: 1N4148
- D27: 1N5408 not on tape !
- D28: 1N5408 not on tape !
- D29: 1N5408 not on tape !
- D30: 1N5408 not on tape !

5. ZENER DIODES

(Check the polarity!)

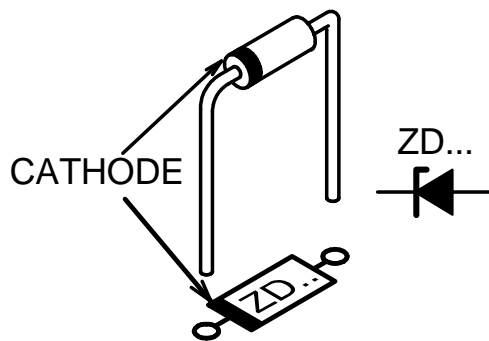

- ZD1: 3V9
- ZD2: 3V9

6. ¼W & ½W RESISTORS

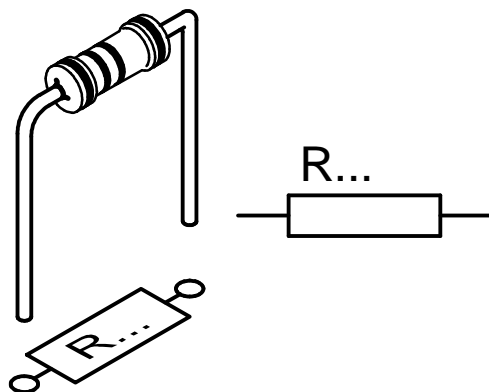

- R1: 470 (4 - 7 - 1 - B)
- R2: 220K (2 - 2 - 4 - B)
- R3: 2K2 (2 - 2 - 2 - B)
- R4: 2K2 (2 - 2 - 2 - B)
- R5: 220K (2 - 2 - 4 - B)
- R6: 100K (1 - 0 - 4 - B)
- R7: 1K (1 - 0 - 2 - B)
- R8: 1K (1 - 0 - 2 - B)
- R9: 22K (2 - 2 - 3 - B)
- R10: 3.3 (3 - 3 - B - B - 9)
- R11: 3K9 (3 - 9 - 2 - B)
- R12: 1K5 (1 - 5 - 2 - B)
- R13: 1M (1 - 0 - 5 - B)
- R14: 1M (1 - 0 - 5 - B)
- R15: 1K (1 - 0 - 2 - B)
- R16: 47K (4 - 7 - 3 - B)
- R17: 470K (4 - 7 - 4 - B)
- R18: 680 (6 - 8 - 1 - B)
- R19: 3K9 (3 - 9 - 2 - B)
- R20: 10K (1 - 0 - 3 - B)

- R21: 10K (1 - 0 - 3 - B)
- R22: 1K5 (1 - 5 - 2 - B)
- R23: 1K2 (1 - 2 - 2 - B)
- R24: 560 (5 - 6 - 1 - B)
- R25: 100K (1 - 0 - 4 - B)
- R26: 220K (2 - 2 - 4 - B)
- R27: 100K (1 - 0 - 4 - B)
- R28: 220K (2 - 2 - 4 - B)
- R29: 10K (1 - 0 - 3 - B)
- R30: 2K7 (2 - 7 - 2 - B)
- R31: 1M5 (1 - 5 - 5 - B)
- R32: 1K5 (1 - 5 - 2 - B)
- R33: 3.3 (3 - 3 - B - B)
- R34: 8K2 (8 - 2 - 2 - B)
- R35: 220K (2 - 2 - 4 - B)
- R36: 10K (1 - 0 - 3 - B)
- R37: 100K (1 - 0 - 4 - B)
- R38: 220K (2 - 2 - 4 - B)
- R39: 100K (1 - 0 - 4 - B)
- R40: 220 (2 - 2 - 1 - B - 9)
- R41: 100K (1 - 0 - 4 - B - 9)
- R42: 47K (4 - 7 - 3 - B - 9)
- R43: 220 (2 - 2 - 1 - B - 9)
- R44: 220 (2 - 2 - 1 - B - 9)
- R45: 220 (2 - 2 - 1 - B - 9)
- R46: 2K2 (2 - 2 - 2 - B - 9)
- R47: 27K (2 - 7 - 3 - B - 9)
- R48: 220 (2 - 2 - 1 - B - 9)
- R49: 220 (2 - 2 - 1 - B - 9)
- R50: 100K (1 - 0 - 4 - B - 9)
- R51: 330K (3 - 3 - 4 - B - 9)
- R52: 330K (3 - 3 - 4 - B - 9)
- R53: 330K (3 - 3 - 4 - B - 9)
- R54: 330K (3 - 3 - 4 - B - 9)

7. 1W RESISTORS

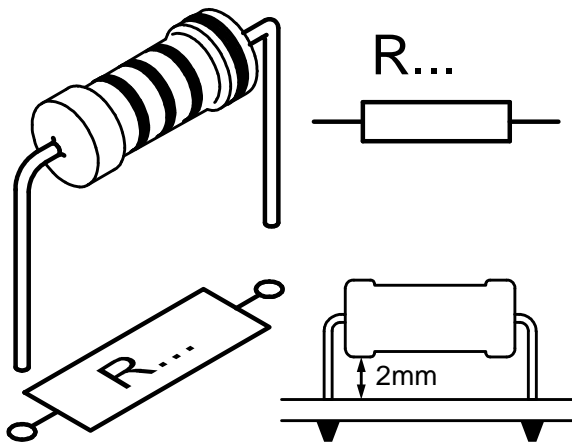

- R55: 270 (2 - 7 - 1 - B)
- R56: 10K (1 - 0 - 3 - B)
- R57: 10K (1 - 0 - 3 - B)
- R58: 12K (1 - 2 - 3 - B)
- R59: 39K (3 - 9 - 3 - B)
- R60: 39K (3 - 9 - 3 - B)
- R61: 39K (3 - 9 - 3 - B)
- R62: 100K (1 - 0 - 4 - B)
- R63: 47K (4 - 7 - 3 - B)
- R64: 47K (4 - 7 - 3 - B)
- R65: 47 (4 - 7 - 0 - B)
- R66: 47 (4 - 7 - 0 - B)
- R67: 180 (1 - 8 - 1 - B)
- R68: 180 (1 - 8 - 1 - B)
- R69: 180 (1 - 8 - 1 - B)
- R70: 47 (4 - 7 - 0 - B)
- R71: 47 (4 - 7 - 0 - B)
- R72: 180 (1 - 8 - 1 - B)

8. LEDs (Check the polarity!)

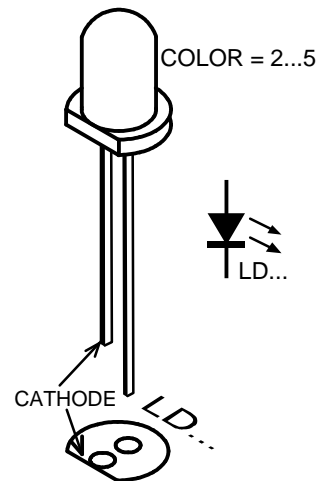

- LD1: 5mm RED (2) BLINKING
- LD2: WILL BE MOUNTED LATER, SEE SECTION 27
- LD3: 3mm YEL (4)
- LD4: 3mm YEL (4)
- LD5: 3mm YEL (4)
- LD6: 3mm YEL (4)
- LD7: 3mm GREEN (5)
- LD8: 3mm GREEN (5)
- LD9: 3mm RED (2)
- LD10: 3mm RED (2)
- LD11: 3mm RED (2)
- LD12: 3mm RED (2)
- LD13: 3mm RED (2) (next to R61)

9. IC SOCKETS

(Check the position of the notch!)

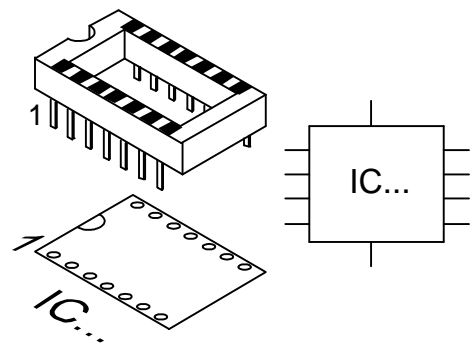

- IC1: 18P

10. REED RELAYS

(Check the position of the notch!)

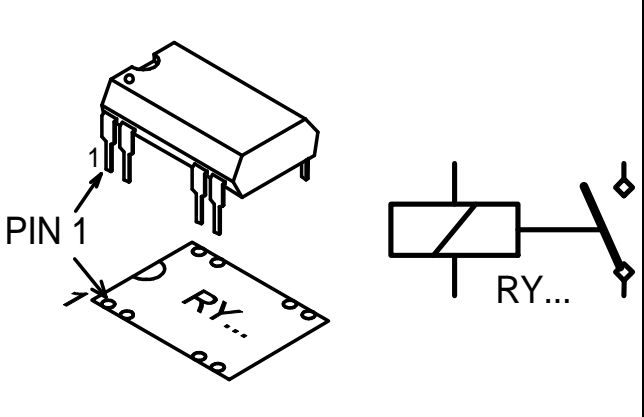

RY1: VR05R121

11. DIP SWITCHES

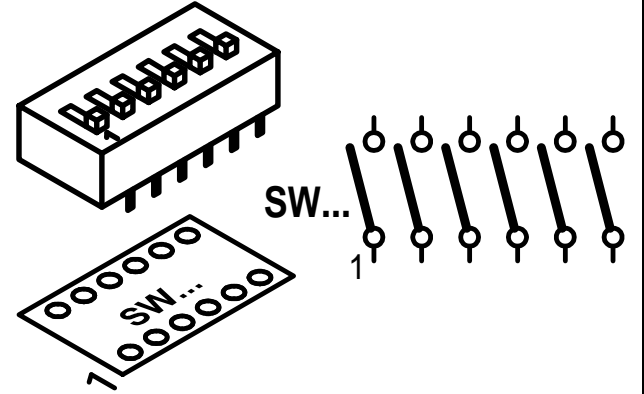

Check that switch 1 corresponds to pin 1.

SW2: DS-4P

12. RESISTOR TRIMMERS

Vertical type

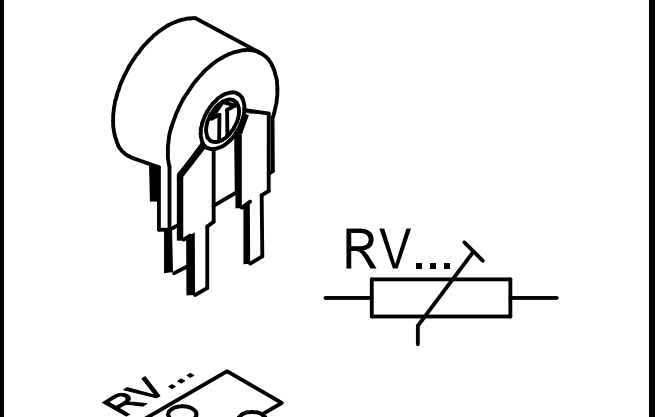

RV1: 100K
 RV2: 100K
 RV3: 100K
 RV4: 100K

Horizontal type

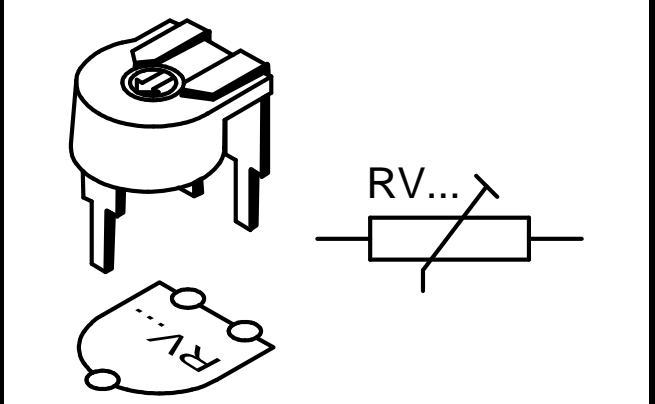

RV5: 500K (470K)

13. TRANSISTORS

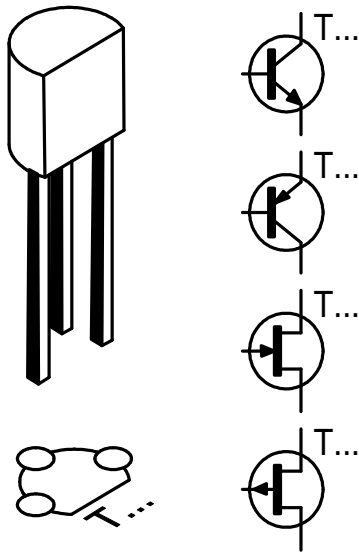

- T1: BC516
- T2: BC547C
- T3: BC547C
- T4: BC547C

15. PCB BLADE TERMINALS

Mount them as straight AS possible against the PCB. A good solder joint is very important !

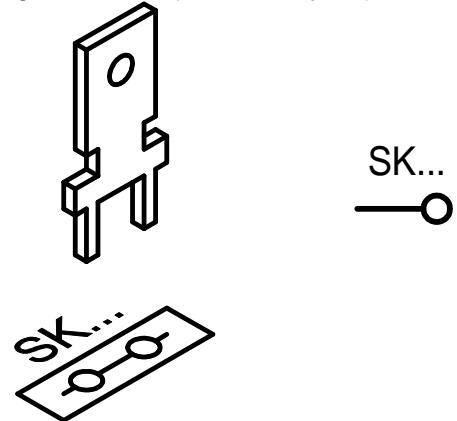

- SK1: 4 Ohm
- SK2: GND
- SK3: 8 Ohm
- SK4: BLUE
- SK5: RED
- SK6: YELLOW
- SK7: GRAY
- SK8: GRAY
- SK9: GREEN
- SK10: GREEN
- SK21: EARTH
- SK22: EARTH

14. 5W RESISTORS

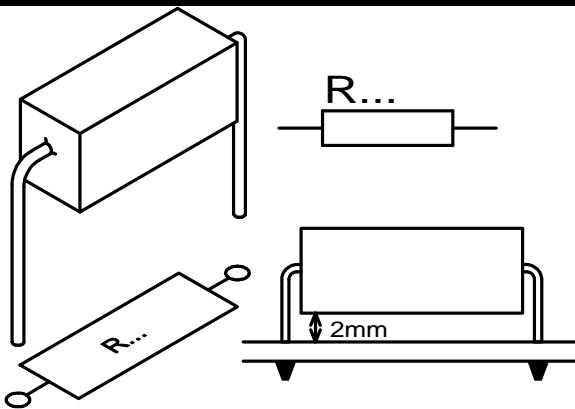

REMARK: You will have one 15 Ohm 5W resistors left over for later use.

- R73: 15
- R74: 15
- R75: 15

16. CINCH / RCA CONNECTOR

Mount it as straight and square as possible against the PCB.

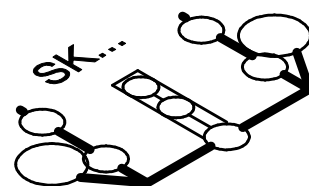
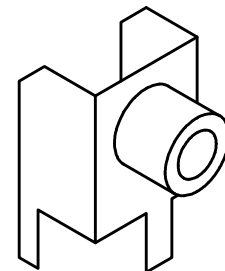

- SK11: CINFP/90

17. PCB TERMINAL BLOCK

some blocks slide into each other !

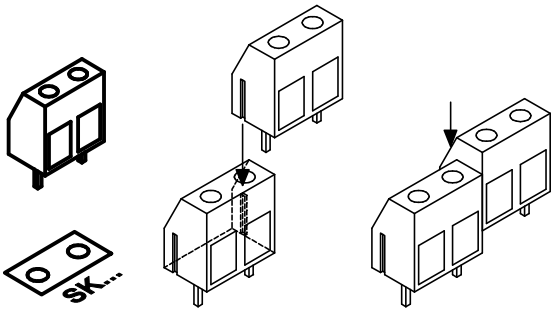

Mount these terminals with the wire inputs facing the PCB edge:

- SK12: 2 POLE (large)
- SK13: 3 POLE
- SK14: 3 POLE
- SK15: 3 POLE
- SK16: 3 POLE
- SK17: 3 POLE

SK18 to SK20 are not mounted

18. VALVE SOCKET

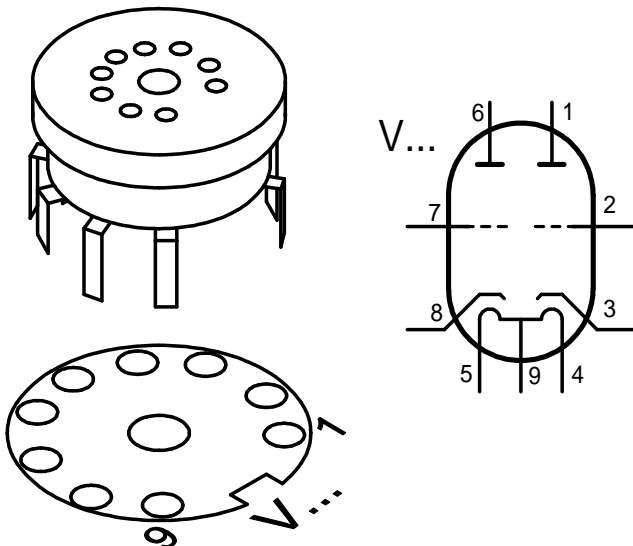

Mount them straight against the PCB

- V5: B9A
- V6: B9A

19. SWITCH

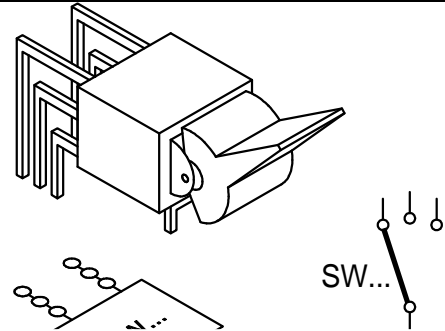

IMPORTANT:
Don't leave a gap between the SWITCH and the PCB!

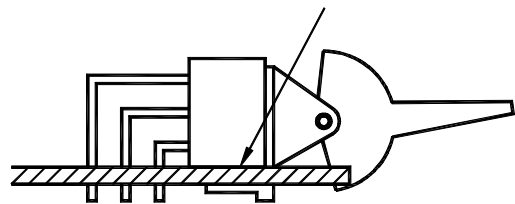

SIDE VIEW

Mount it as square as possible against the PCB, Also solder the metal support.

- SW1: 3P ON-ON-ON

20. CAPACITORS

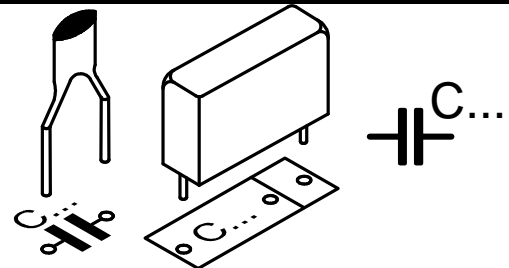

Check the voltage rating!

- C1: 47nF (473, 0.047, 47000)
- C2: 100pF (101)
- C3: 330pF/400V (331)
- C4: 330pF/400V (331)
- C5: 68n/630V (683, 0.068)
- C6: 68n/630V (683, 0.068)
- C7: 68n/630V (683, 0.068)
- C8: 68n/630V (683, 0.068)
- C9: 68n/630V (683, 0.068)
- C10: 68n/630V (683, 0.068)
- C11: 680n/160V (684, 0.68)
- C12: 680n/160V (684, 0.68)
- C13: 680n/160V (684, 0.68)

21. POWER RELAYS

The various relays have footprints that correspond to the footprints on the PCB:

- RY2: VR10V121C
- RY3: VR10V121C

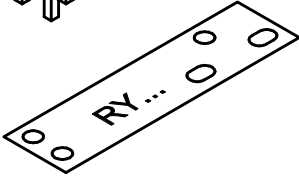
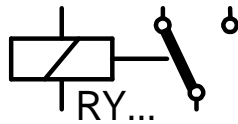
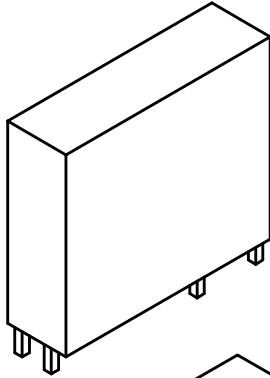

- RY4: VR5V122C

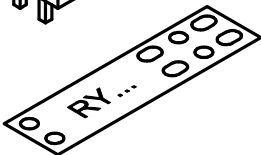
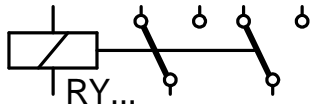
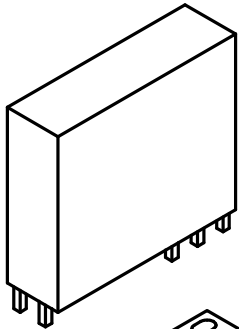

22. ELECTROLYTIC CAPACITOR (Check the polarity!)

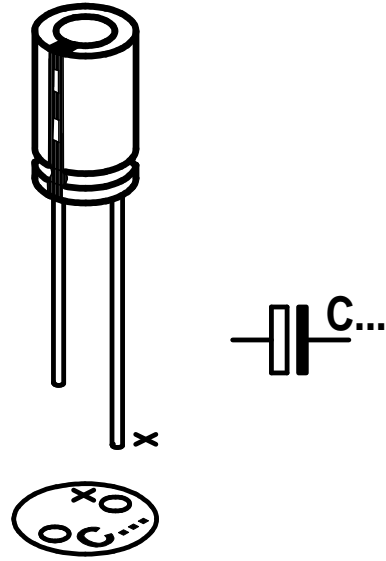

- C14: 4 μ 7
- C15: 100 μ F
- C16: 470 μ F
- C17: 470 μ F
- C18: 470 μ F
- C19: 470 μ F
- C20: 47 μ F/100V
- C21: 100 μ F/100V
- C22: 1000 μ F
- C23: 4700 μ F
- C24: 47 μ F/350V
- C25: 47 μ F/350V
- C26: 100 μ F
- C27: 1 μ F

23. TRANSFORMER

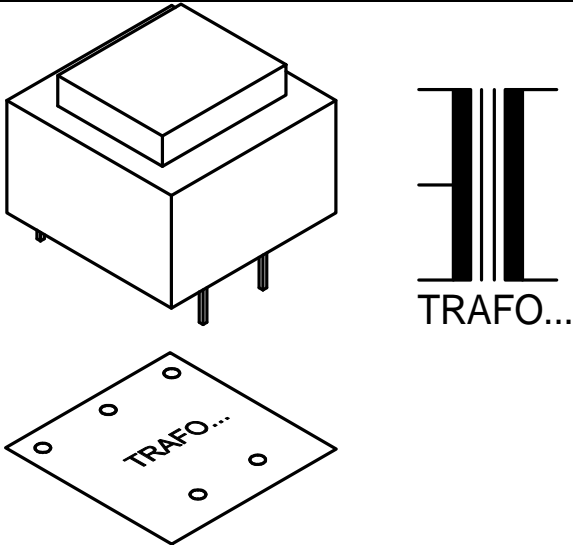

- TRAFO1: 12VAC

25. INSERT THE IC (Check the position of the notch!)

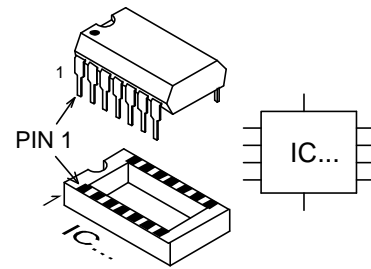

- IC1: LM3914

24. ELECTROLYTIC CAPACITOR (Check the polarity!)

Generally these capacitors are of the snap-in type and cannot be mounted incorrectly.

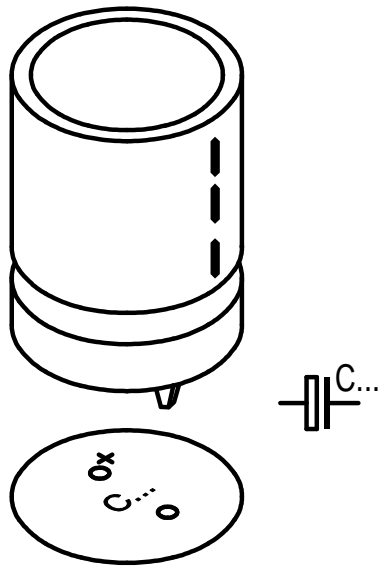

- C28: 100u/400V
- C29: 220u/450V
- C30: 220u/450V
- C31: 220u/450V

26. 6.3V VALVE WIRING

- Wiring for the 4 valve sockets V1 to V4. Use the supplied brown wire. Twist them as shown in the illustration. The polarity is not important. For safety, it is advisable to check with an ohmmeter that the two 6.3V terminals are not shorted when the wiring is completed.

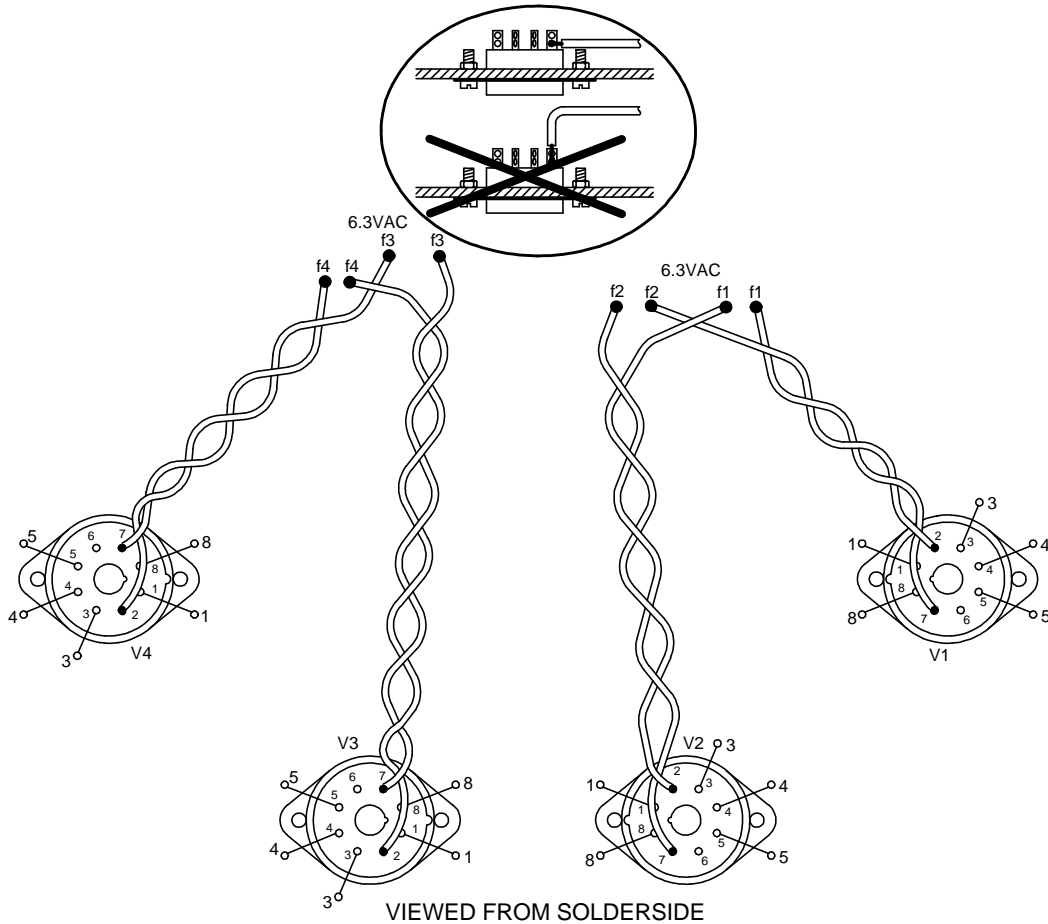

27. SPECIAL LED (Check the polarity!)

- LD2: 3mm bicolor:
 Carefully check the mounting of this LED:

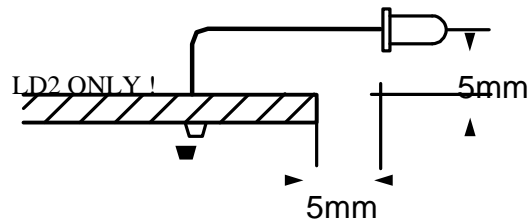
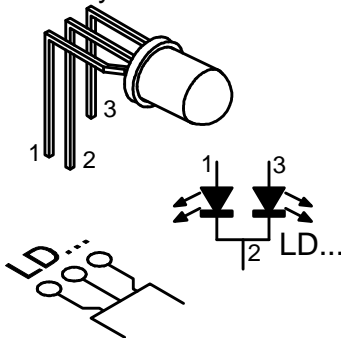

Check the complete assembly again for errors. Pay special attention to bad solder joints, shorts and wrongly inserted or misplaced components !

ASSEMBLY INTO THE CABINET:

- Mount the caged nuts into the square holes as shown in the illustration. These nuts are later used to fasten the covers.

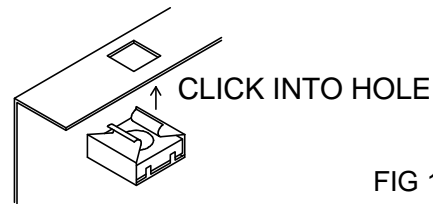

FIG 1

- Mount the chromed feet on the four cabinet corners, with an M4 bolt. To avoid scratches on other equipment, you can stick a piece of felt on every foot (not supplied).
- Mount a shakeproof washer and a 15mm threaded spacer on the front and back studding as shown in the illustration.

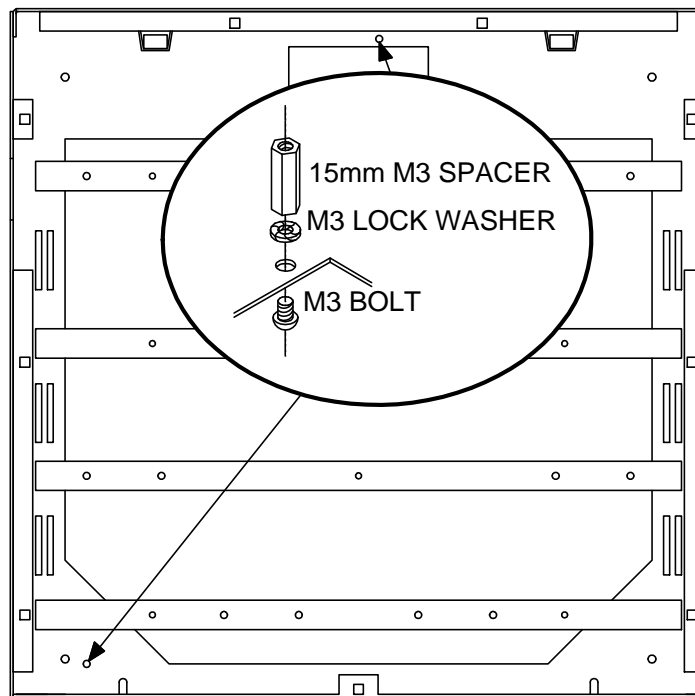

FIG 2

- Position the PCB in the cabinet, and fasten at the bottom with the supplied black button head hexagon socket screws (Use the supplied Allen key). At the component side of the PCB, two M3 bolts fasten the PCB on the threaded spacers we mounted in the previous step.
- The mains inlet located at the back of the enclosure will be flush mounted as shown in the illustration. Use two black button head hexagon socket screws, together with a shakeproof washer and an M3 nut.

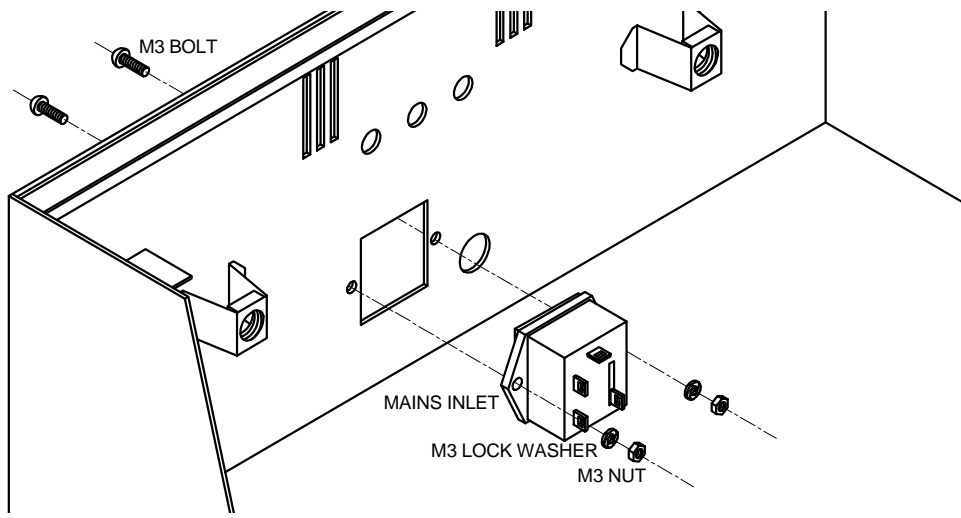

FIG 3

- Make the connections as shown. Use the supplied blue wire for the neutral (N) terminal, and brown wire for the live (L) terminal.

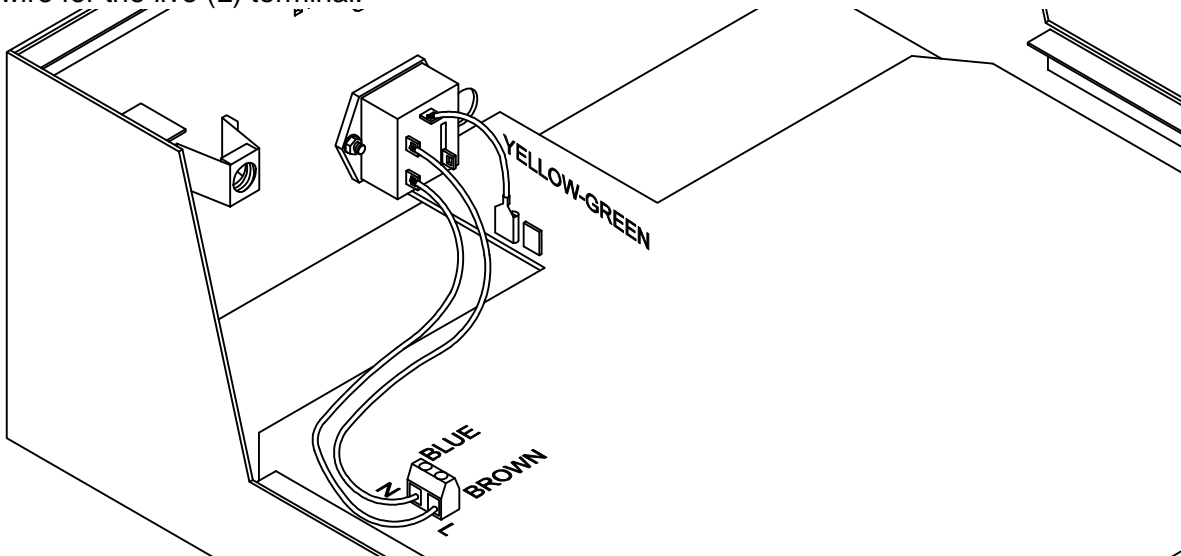

FIG 4

The earth terminal is hooked up with green/yellow striped wire. The female push-on connector on the green/yellow striped wire must be soldered for best results.

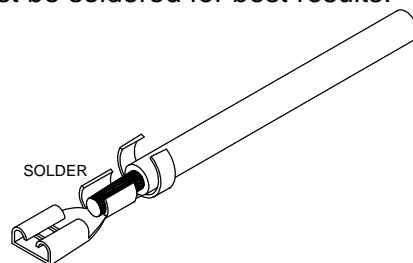

FIG 5

Connect the earth wire to SK21 on the PCB. Remove the fuse holder lid, and insert a miniature glass fuse. For mains voltages of 100-125VAC, use the supplied 8A slow-blow fuse, while for 220-240VAC operation the 4A slow-blow fuse needs to be fitted. The spare fuse can also be stored in the fuse holder lid.

- Mounting of the speaker terminals: Mount them as shown in the diagram. Watch the position of the plastic insulator rings : one is flat, while the other has an elevated ring on the inside. There is no need to mount the solder lugs.

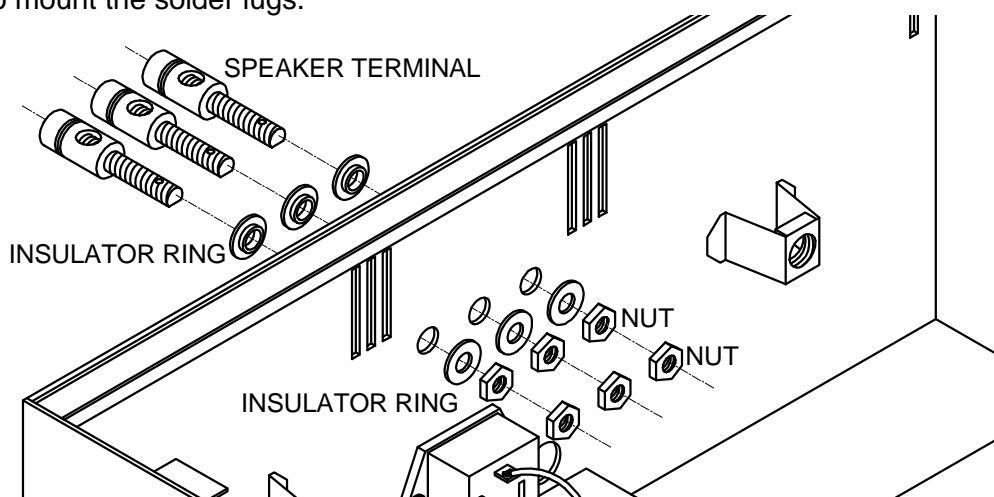

FIG 6

HINT : For easy fastening of the speaker terminals, immobilise the terminal by inserting a screwdriver in the wire hole, while fastening the nuts.

IMPORTANT: The speaker terminals must be electrically isolated from the metal enclosure. For safety, check for infinite resistance between every terminal and the metal enclosure.

- Use the supplied 1,5mm² wire to make the connections. For best results, solder the female push-on connector (fig 5). Apply enough heat, in order to make a good solder joint.

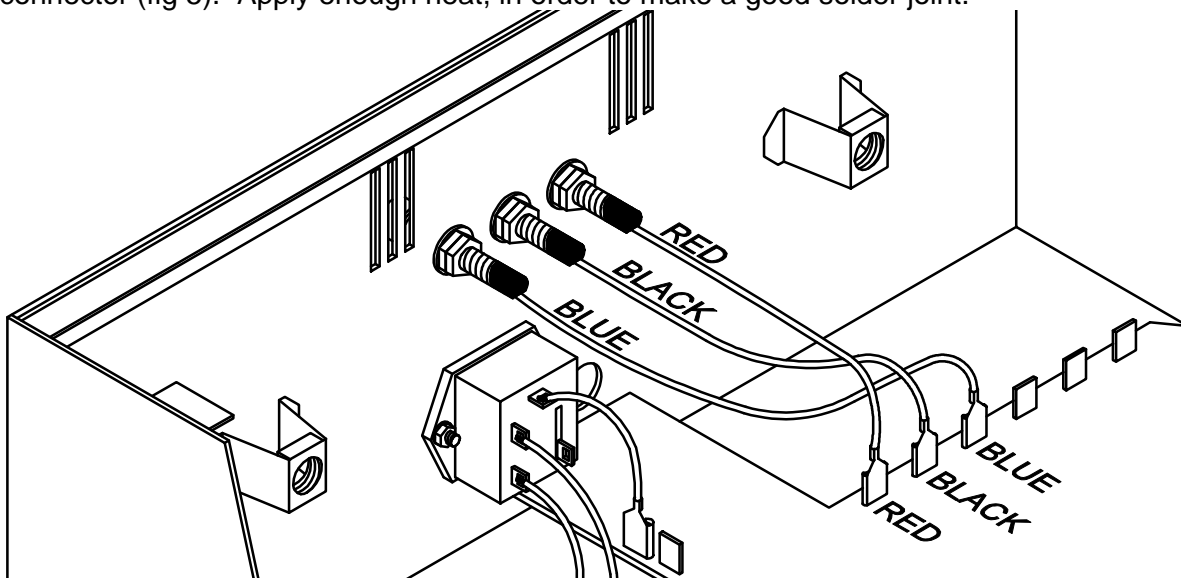

FIG 7

- Mounting of the toroid transformers : The output transformer marked ZD043 must be fitted according to the illustration, on the right hand side of the cabinet. Watch the location of the wires.

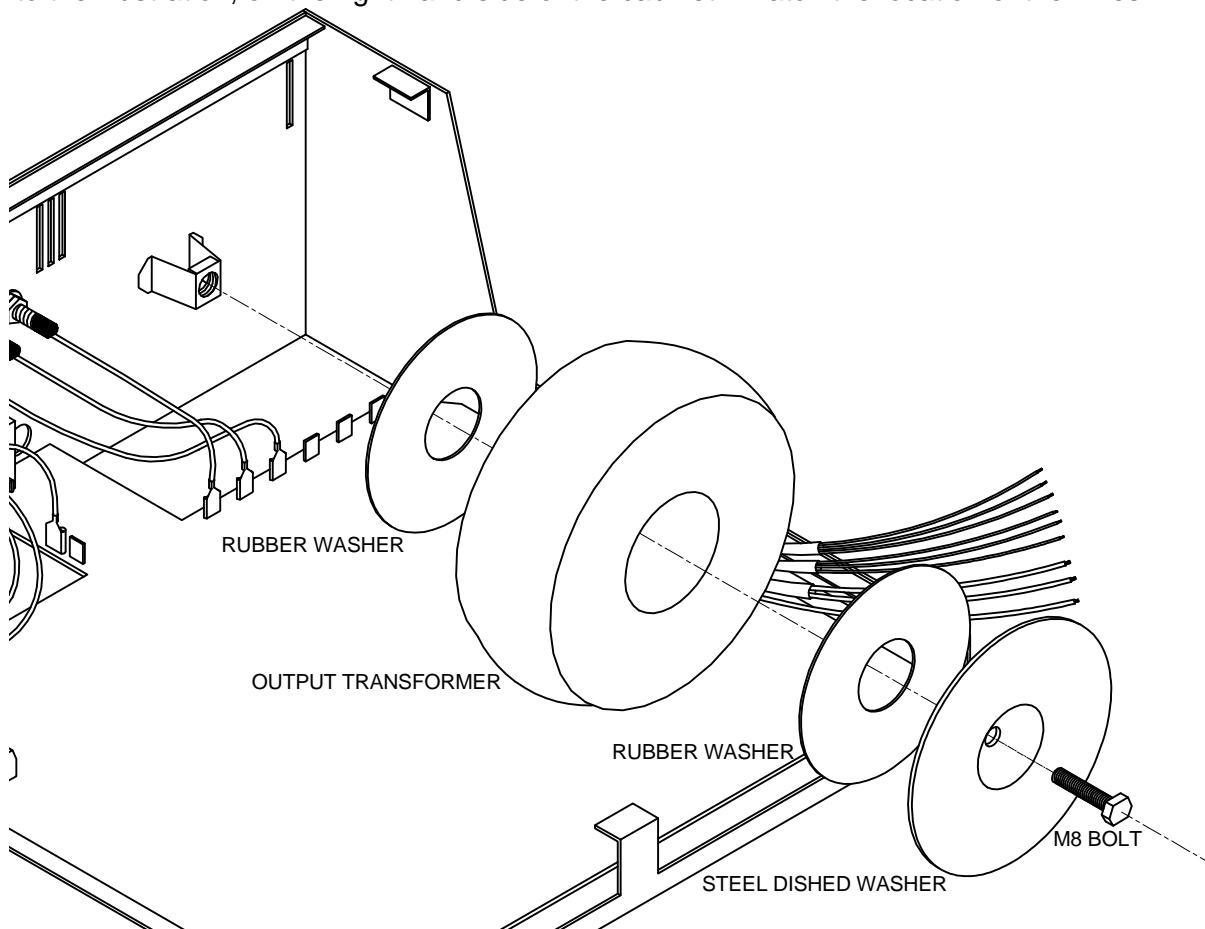



FIG 8

IMPORTANT: Do not trim the wires of the transformers, leave them at their original length. If there is more than one conductor in an insulating sleeve, you have to make sure they are soldered together and make a good electrical connection before they are connected to the terminal block.

- Connect the double yellow wire with the connector marked 'YELLOW' SK6.
 Connect the red wire with the connector marked 'RED' SK5.
 Connect the blue wire with the connector marked 'BLUE' SK4.
 Use the supplied female push-on connectors (fig 5) and solder them onto the wires !
 Connect the remaining wires to the terminal blocks SK16 and SK17. Pay attention to the colors.

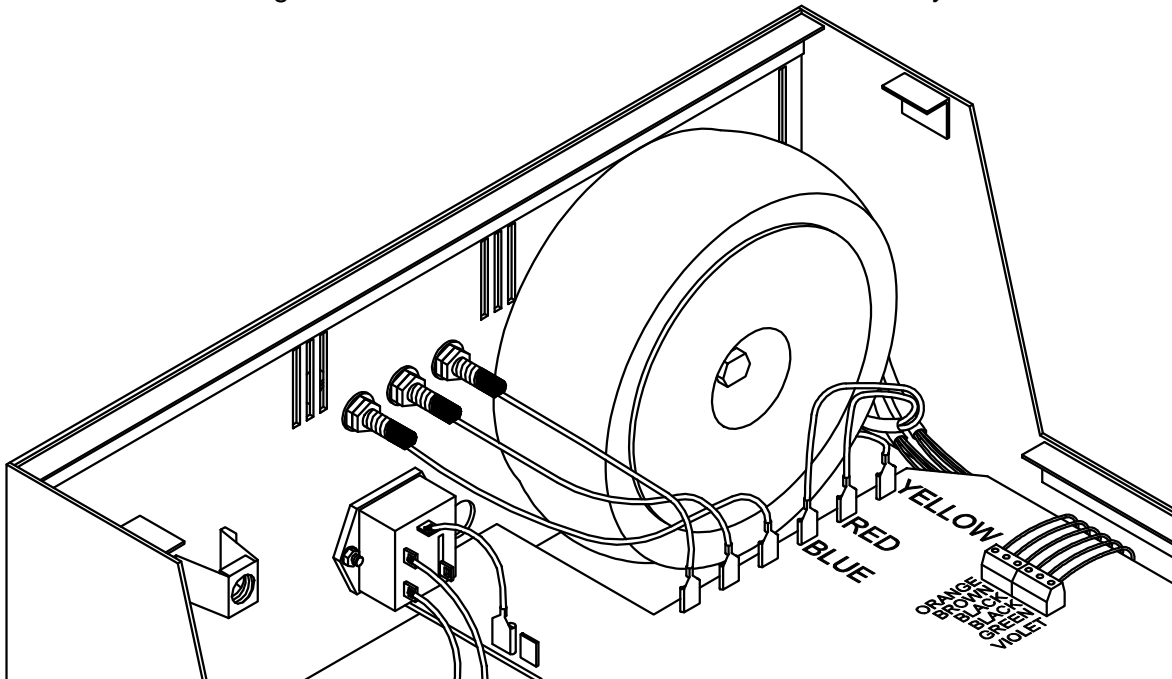

FIG 9

- The supply transformer must be fitted according to the illustration, on the left hand side of the cabinet. Watch the location of the wires. The sturdy grey and green wires, which supply the 6,3V filament voltage, must sit on top.

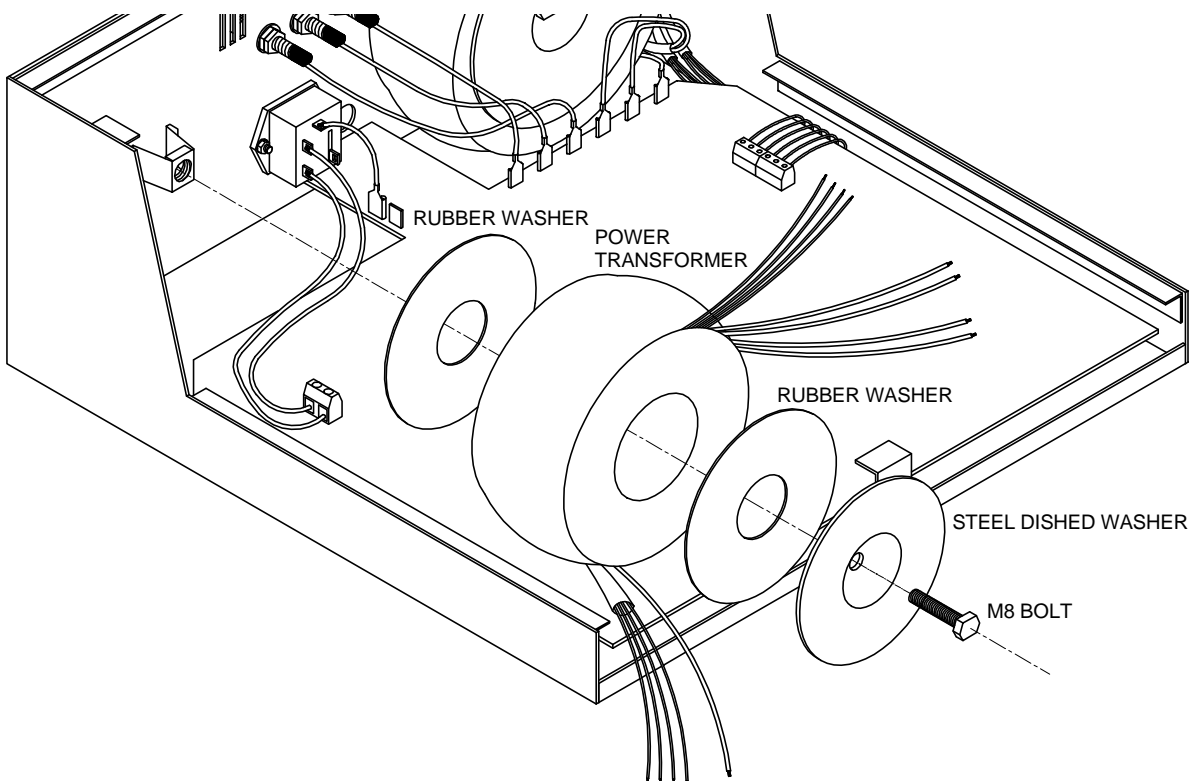
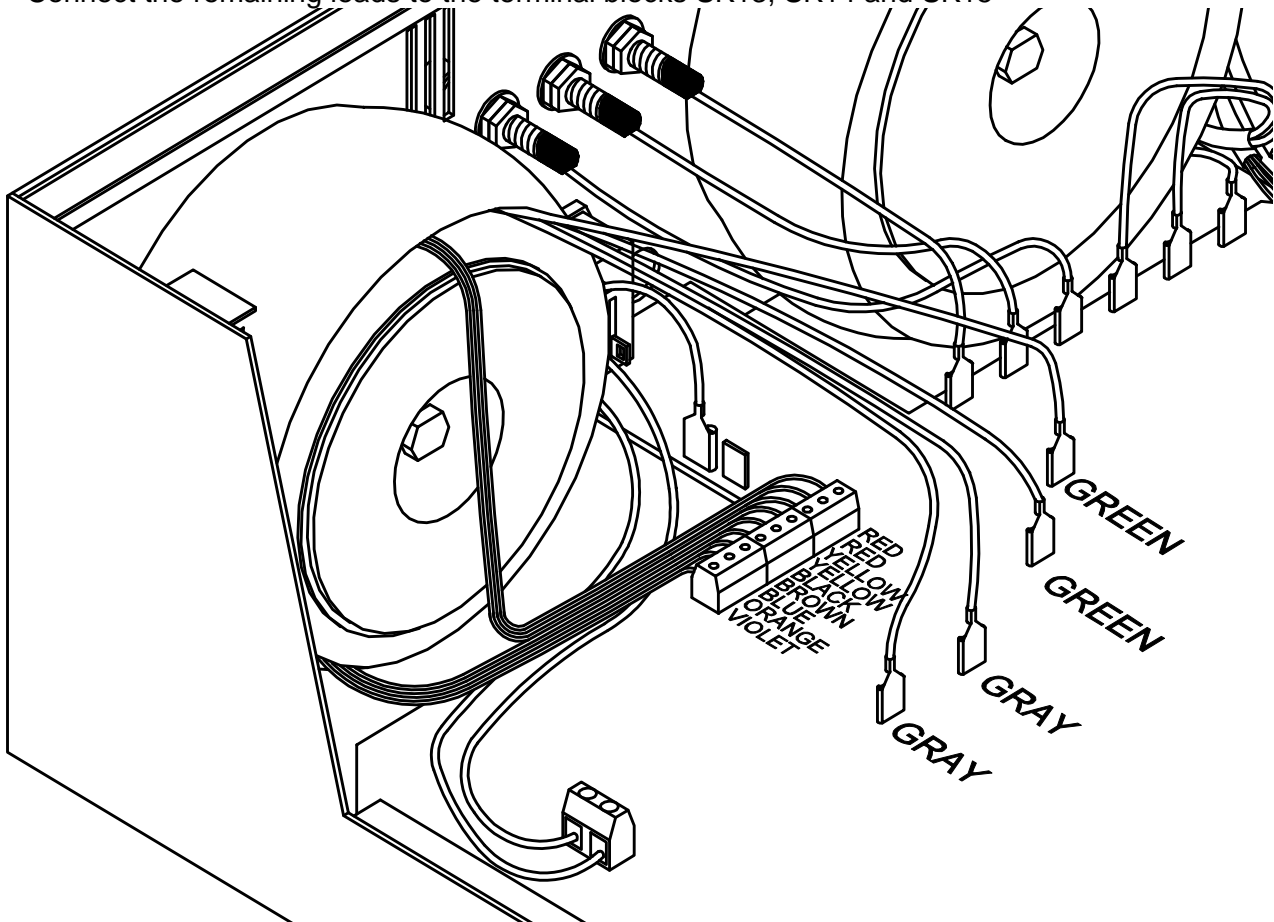

FIG 10

- Connect the grey wires to the connectors marked SK7 and SK8 (**GRAY**). Connect the green wires to the connectors marked SK9 and SK10 (**GREEN**).
Connect the remaining leads to the terminal blocks SK13, SK14 and SK15



11

FIG

FINAL INSPECTION :

WARNING : THE PCB CARRIES VOLTAGES THAT EXCEED 400V !
THESE VOLTAGES CAN KILL ! MAKE SURE NO ONE CAN TOUCH ANY LIVE PARTS
Use suitable isolated measuring equipment

- Put the mains switch into its fully OFF position (all the way down).
- Connect the unit to a wall outlet, by means of the supplied cord. In some countries, the supplied plug will not fit the local wall outlets. If this is the case, cut the supplied plug, and replace it with a suitable one (not included). Make sure to wire it correctly : blue : neutral (N), brown : live (L), yellow/green : earth.
If the mains voltage is present, LD2 should light continuously red.
- Turn the unit on by pushing the mains switch to its fully upward position.
LD2 should now blink for a while, this indicates the standby mode. After approximately one minute, LD2 should light continuously green, indicating 'ON', and a relay should click.
- Now check the following voltages with a multimeter:
Measure about 6.3VAC between SK7-SK8 and SK9-SK10
Measure about 6.3VAC between pins 2 and 7 of the tube sockets V1 to V4 (illustration)

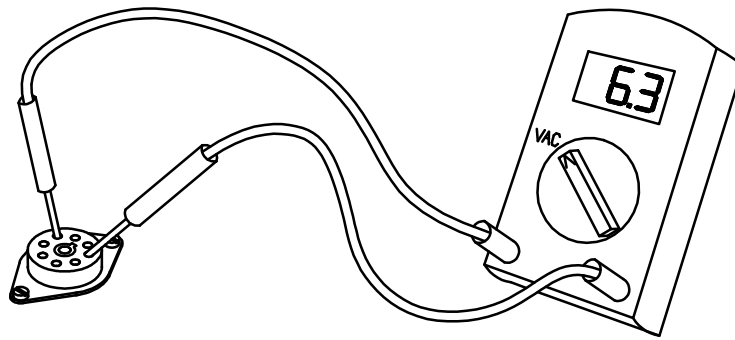

FIG 12



SWITCH OFF THE UNIT AND REMOVE THE MAINS PLUG. WAIT A COUPLE OF MINUTES UNTIL THE DANGEROUS HIGH VOLTAGE HAS DISSAPEARED (UNTIL HIGH VOLTAGE INDICATOR LD13 TURNS OFF)

- Put the small valves in place:
V6 type ECC82 or 12AU7, CV491, 6189, 8136
V5 type ECC81 or 12AT7, CV455, 6201, 8162
- Reconnect the mains plug, and switch the unit ON again (switch in full upward position)
Wait until LD2 lights green continuously.
- Now check all indicated voltages on the PCB with respect to ground. A suitable ground for these measurements is J4, at the centre of the PCB. The point indicated VB2 should carry approx. 3.5VDC.

REMARK : All voltages may vary a bit, due to mains voltage fluctuations. At this stage, you cannot measure the 3.6VDC voltages yet.

CALIBRATION

Switch off the unit, disconnect the mains plug and wait until the high voltage has disappeared. Turn the trim potentiometers RV1 to RV4 fully counter clockwise with a small screwdriver. Put the four KT88 or equal tubes in their sockets. Watch the position of the notch.

IMPORTANT : The remaining 15 Ohm / 5W resistor must be hooked up between the centre and the 8 ohm speaker terminal at the back of the unit. A valve amplifier must **never** be operated without a suitable load at the speaker terminals. Make sure there is a good electrical connection between the terminals and the resistor.

Bias current calibration

This calibration does not require a measuring instrument, as the bias level of each tube can be displayed on the LED scale. The four dipswitches allow valve selection, while each valve has its own trim potentiometer. RV1 controls V1, RV2 controls V2 etc...

IMPORTANT : This calibration determines the bias current trough the expensive output valves. Therefore, it requires your absolute attention. Perform the calibration in the correct order. No signal may be present at the input of the amplifier, during the calibration.

Flip all four DIP switches (SW2) to their OFF position

Every switch enables the bias readout of one valve, so do not switch on more than one at a time, or the readout will be incorrect.

Reconnect the mains plug, and switch the unit ON again (switch in full upward position)
Wait until LD2 lights green continuously.

Put the first switch in the ON position (use a pen or a small screwdriver)
Gently turn RV1 clockwise until the second or third LED lights (LD4 or LD5)
Switch off the first switch.
Switch on the second switch
Gently turn RV2 clockwise until the second or third LED lights (LD4 or LD5)

Perform the same operation with RV3 and RV4

Wait for about 10 minutes, before continuing the rest of the calibration.

Repeat the calibration of RV1 to RV4, but this time the trim potentiometers must be turned clockwise until one or two green LEDs light.

When this operation is finished, check the 3.6V DC voltages at R65, R66, R70 and R71. Again, use J4 as ground reference.

FINALLY !

It is time to listen to your amplifier !

Switch off the unit completely before connecting or disconnecting any cables.

Connect a 4 or 8 ohm speaker to the correct terminals at the back of the unit. Speakers with impedances between 4 and 8 ohms can be connected to the 8 ohm terminal.

The common negative speaker terminal is located in between the 4 and 8 ohm positive terminals.

Hook up an audio source to the RCA connector at the back. Make sure the volume control of the source is set to minimum before the unit is turned on.

The 'SENSITIVITY' trimmer located at the centre of the board allows you to trim the amplifiers input sensitivity, so two units put out exactly the same level, which improves the stereo image. Normally, this trimmer should be set fully clockwise.

If necessary, feed a mono signal to both amplifiers, and trim both sensitivity trimmers, until the sound comes from the exact centre between both loudspeakers.

- **Valve amplifiers run hot ! Operate them in a well ventilated area ! Do not put them in a closed rack, stack or cabinet.**
- **It is a good habit to check the bias current on a regular basis, especially when the valves are new.**
- **They need to run-in for a while, during which the bias level may shift.**
- **For short intervals between listening sessions, put the amplifier in stand-by mode (mains switch in middle position).**

FINISHING THE ENCLOSURE ASSEMBLY

- Check if none of the components on the PCB will touch the chromed cover plates, when they are put in place.
- Turn the unit, so it rests on its left or right hand side.
- This allows you to fasten the bottom lid, by means of the supplied black button head hexagon socket screws.
- Click the caged nuts into their holes on the chromed vertical plate (Be careful not to scratch the surface).
- Mount the chromed cover plate on the chromed vertical plate with two silver button head hexagon socket screws. Tighten by hand.
- Position this assembly onto the enclosure, and put the silver button head hexagon socket screws in place. Tighten them by hand. Connect the chromed vertical plate to SK22 (chassis earth) with a

length of yellow/green striped wire and 2 female push-on terminals. Make sure you solder both terminals. (See fig 5)

- Mount the top cover on the enclosure (Make sure the earth lead of the vertical plate is bent down, so it does not get squeezed between the lid and the enclosure). Use the supplied black button head hexagon socket screws.
- Mount the front panel. Use the supplied right angle mounting brackets, together with the shakeproof washers and the M3 and M4 bolts. Take care of the correct position of the mains switch and LD2.
- Make sure everything fits well, and tighten all screws.



**THIS AMPLIFIER RUNS HOT, OPERATE IT OUT OF THE REACH OF CHILDREN !
CHECK YOUR MAINS VOLTAGE**

MAKE SURE IT MATCHES THE SELECTED VOLTAGE

**REMOVE THE MAINS PLUG AND WAIT AT LEAST 15 MINUTES BEFORE REMOVING THE
COVERS**

SOME PARTS MAY CARRY DANGEROUS VOLTAGES, EVEN WHEN THE UNIT IS UNPLUGGED

TROUBLESHOOTING

Hum coming from the speakers :

To make sure the amplifier is the source of hum, short the RCA input (by means of a spare male RCA plug, which you short internally), and disconnect the earth connector SK21.

As a reference, listen at about 1m (3 ft) from the speaker, there should be an negligible amount of hum present.

If there's still a reasonable amount of hum present, check the bias current of every valve. Also check the electrical connection between the PCB ground and the enclosure, which is done trough the bolt next to R1.

A defective valve can also be a source of hum.

If hum is only present, when the amplifier is hooked up to an audio system, then a hum-loop could be the cause. To verify if this is the case, disconnect SK21

Use good quality, as short as possible, interconnecting leads.

For best results, choose equal lengths for both left and right amplifier.

If the high tension is not present, check the transformer wiring and the mains fuse, located at the back of the unit, below the mains inlet.

An intermitted crackling sound coming from the speakers could point to a defective resistor R62.

Replace it with the same value and power rating.

A continuous buzzing sound coming from the speakers or a crackling sound during bass peaks could be caused by oscillation of the amplifier.

In this case, try raising the value of R46 (e.g. 2K7 or even 3K3). This will also slightly increase the input sensitivity.

If your speaker system includes a piezo driver, make sure it has a 10 ohm/ 1W resistor in series with the unit.

THE MODIFICATIONS MENTIONED ABOVE ARE ONLY TO BE PERFORMED WHEN REPEATED INSPECTION OF THE CIRCUIT BOARD, SOLDER JOINTS AND WIRING DID NOT POINT TO ANY OBVIOUS FAULTS OR MISTAKES OF ANY KIND.

REMARK: Valves are very sensitive to mechanical shocks. Therefore, we recommend not to move the unit when the valves are hot. Always let them cool down for a while. Avoid sudden temperature changes, e.g. when the unit is moved from a cold room to a heated room. Always leave it idle for a while, so it can adapt to the new environmental condition.

A valve that breaks down starts glowing cherry red. Turn off the unit immediately. Usually, the 47 ohm/1W cathode resistor of the defective valve will also need replacement.

If you have the impression that for some reason, the unit still does not operate as it should, you can send it to our technical dept. for inspection. Send the PCB only, not the enclosure or the transformers. Use the original box. Include a detailed description of the fault. Check www.velleman-kit.com for your nearest Velleman dealer.

Velleman wishes you many hours of listening pleasure !

DIAGRAMS

